

Heavy Duty Work Lights

ABL 500 LED 3000

- designed to exceed everyday demands in all applications
- stringent engineering and testing practices
- highest efficiency and durability in the harshest conditions



Premium lighting solutions



Heavy Duty - Work Lights

ABL 500 LED 3000

The ABL 500 LED series work lights are designed to exceed everyday demands in all applications. Through stringent engineering and testing practices, we ensure the highest efficiency and durability in even the harshest operating conditions.

Dimensions

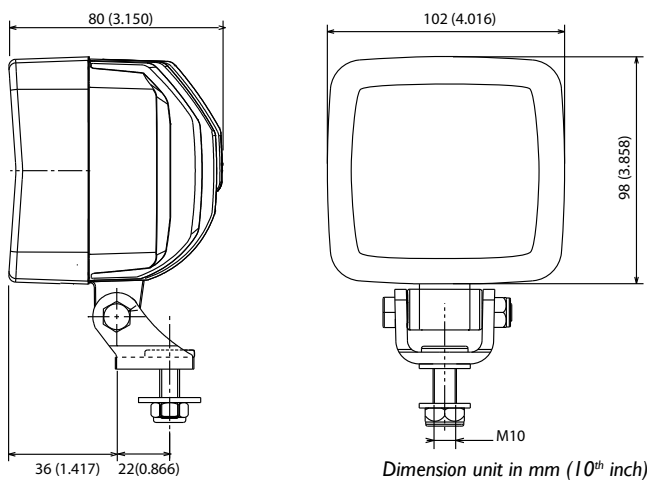

Dimension unit in mm (10th inch)



Light Patterns

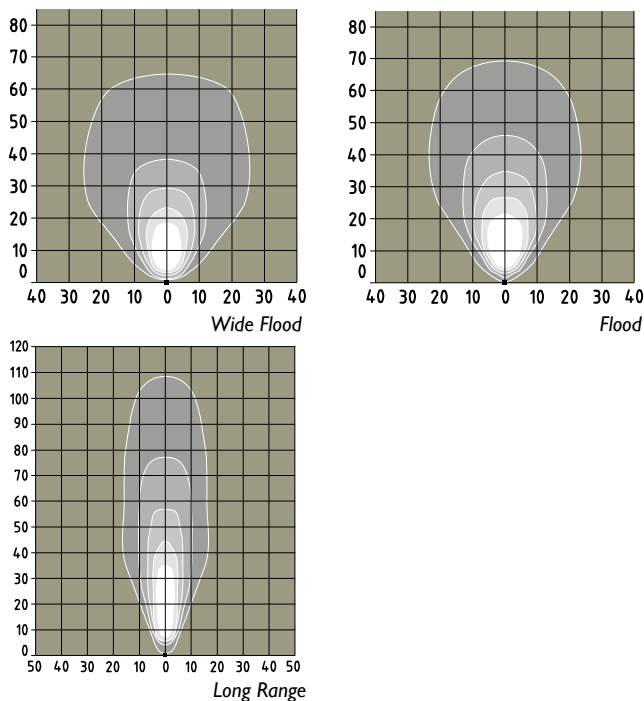

Specifications

Bulb:	6 LED - 3000 Lumen
Lifetime:	20 000 hours
Color temperature:	6000K
Light pattern:	Wide Flood, Flood, Long Range
Consumption:	36W
Voltage:	Multi 12-100V
Intensity:	1,5 Amp @ 24V
Weight:	0,9 Kg
Vibration resistance:	15 Grms from 24 to 2000Hz
Shock resistance:	60 G
EMC:	ISO 13 766 - ISO 14 982 - ISO 12 895
Load Dump:	130V continuous 200V 100 ms 1800V 50 μs
Polarity:	protected against reverse voltage
Electronic Thermal Management:	full output @ +35°C ambient 20% dimmed @ +50°C ambient
Water Tightness:	IP 68 - IP 69K
Operating Temp:	-40°C to +85°C
Salt Spray:	ISO 9227
Lens:	hardened glass
Reflector:	multi lens system
Warranty:	20 000 operating hours or 4 years

Connection



Built-in AMP 2 ways

Built-in DT 2 ways

Options

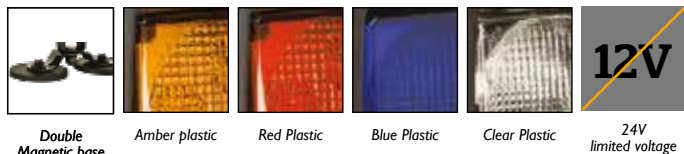

Mounting

