

Heavy Duty Work Lights ABL 500 LED Blue

- ensures a visible sharp-edged warning signal on the floor
- for an increased safety environment
- also available in Red version





Heavy Duty - Work Lights

ABL 500 LED Blue

The ABL 500 LED series work lights are designed to exceed everyday demands in all applications. This specific Blue version of our LED worklight range ensures a visible sharp-edged warning signal on the floor for an increased safety environment.

Dimensions

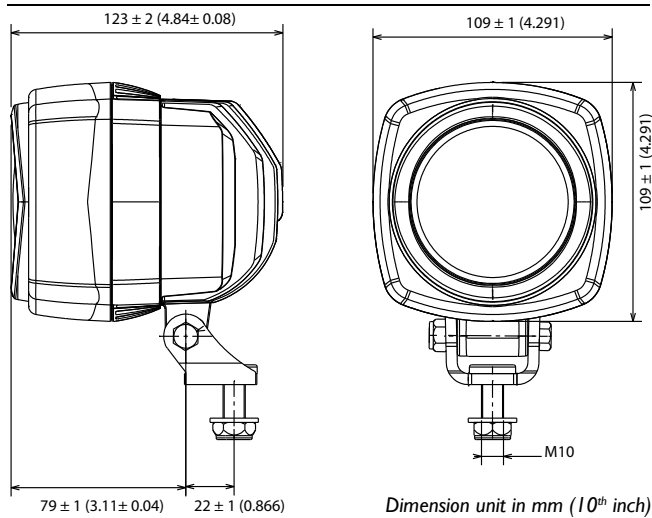

Specifications

Bulb:	LED Blue - LED Red optional
Lifetime:	20 000 hours
Light pattern:	Sharp-edged Spot
Consumption:	5W
Voltage:	Multi 12-100V
Intensity:	0,2 Amp @ 24V
Weight:	1,0 Kg
Vibration resistance:	10 Grms, from 24Hz to 2000Hz
EMC:	ISO 12 895
Load Dump:	130V continuous 200V 100 ms 1800 V 50 µs
Polarity:	no polarity
Water Tightness:	IP 68 - IP 69K
Operating Temp:	-40°C to +85°C
Salt Spray:	ISO 9227
Lens:	PC lens
Warranty:	20 000 operating hours or 4 years

Application

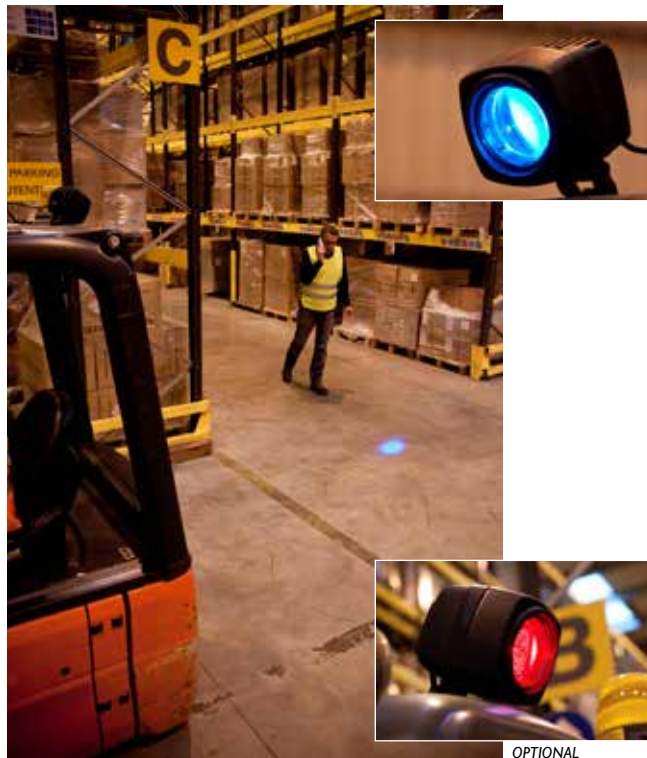

Connection



Options



Mounting

